

# RIEGL VQ<sup>®</sup>-820-G

- *excellently suited for combined land and hydrographic airborne survey*
- *high-accuracy ranging based on echo digitization and online waveform processing with multiple target capability*
- *high spatial resolution due to laser repetition rate up to 520 kHz, high scanning speed up to 200 scanlines/second and a wide field of view up to 60°*
- *compact, rugged and light-weight modular configuration, compatible with standard airborne platforms.*
- *optional waveform data output, data accessible via RiWAVELiB*
- *seamless integration with other RIEGL ALS Systems and software packages*

Repetitive surveying of inshore waters is becoming more and more essential to evaluate reservoir sedimentation, river degradation, water flow and water level dynamics, structure and zone variations of rivers and riparian areas. This can only be achieved in an effective way by employing high-resolution hydrographic airborne laser scanning.

The RIEGL VQ-820-G Hydrographic Airborne Laser Scanner is specifically designed to survey seabeds or ground of rivers or lakes. Integrated into a Complete Platform for Airborne Scanning, it can easily be installed in any type of aircraft, e.g. fixed wing or helicopter.

Laser range measurements for high resolution surveying of underwater topography, the bottom of shallow waters and riverbeds, are carried out with a narrow, visible green laser beam at 532 nm, emitted from a powerful laser source. Depending on water turbidity this particular laser wavelength allows measuring into water.

To handle target situations with complex multiple echo signals, the RIEGL VQ-820-G gives access to detailed target parameters by digitizing the echo signal and performing RIEGL's highly developed online waveform processing.

#### Typical applications include

- *Coastline and Shallow Water Mapping*
- *River Bed Profiling*
- *Acquiring Base Data for Flood Prevention*
- *Measurement for Aggradation Zones*
- *Habitat Mapping*
- *Surveying for Hydraulic Engineering*
- *Monitoring of Hydraulics Laboratories*
- *Hydro-Archaeological-Surveying*

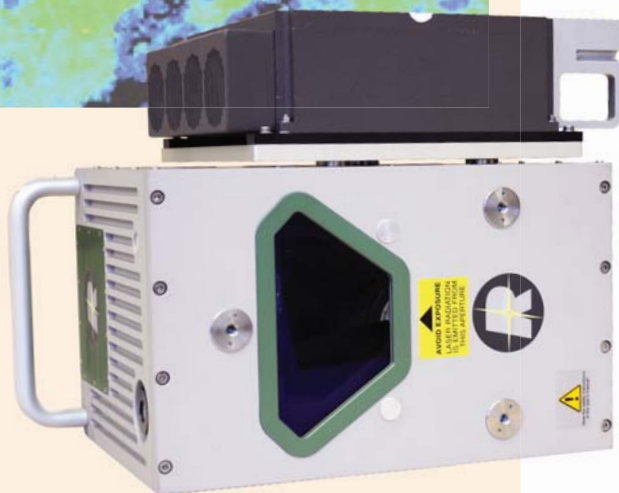

visit our website  
[www.riegl.com](http://www.riegl.com)

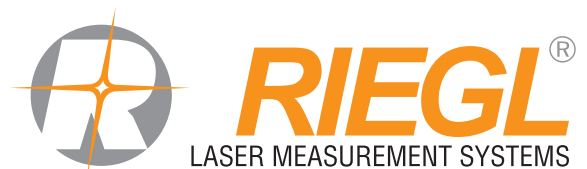

## Design

The RIEGL VQ-820-G consists of an unrivalled compact and lightweight scan head connected to a powerful laser source via an armored glass fiber cable and electrical cables, allowing easy installation into existing and certified airborne scanning platforms and hatches of standard size with similar key data for Fit, Form & Function, as well as in terms of power supply requirements and weight & balance considerations - total weight is approx. 26 kg, power consumption is less than 200 W.

The scan mechanism of the VQ-820-G is based on a rotating multi-facet mirror where the scan axis is tilted by about 20° with respect to the nominal flight direction, so that the angle of incidence of the laser beam to the water surface varies only by about 1° over the entire scan range of up to 60°. This results in an arc-like scan pattern on ground.

Aiming at high resolution, the laser scanner emits a narrow beam of about 1 cm diameter with a beam divergence in the range of 1 mrad. Therefore, at the nominal flight altitude of 600 m, the spatial resolution as defined by the laser beam geometry is in the range of 60 cm. High spatial resolution is also supported by an exceptionally high net measurement rate of 200,000 measurements per second.

## Echo Analysis

The incoming echoes are digitized at a sampling rate matched to the pulse width. The instrument is equipped with online waveform processing. Concurrently echo waveform data can be stored for full waveform post processing by means of the optional waveform data output. For each trigger event a so called sample block containing a certain number of samples before and after the trigger event is recorded.

For every target echo, the position, amplitude, and pulse deviation are determined. If the echo pulse is severely deteriorated by turbidity or multi-target returns, this will be signaled through an increased value of the scanner's pulse deviation reading and the corresponding waveform can then be analyzed with more sophisticated algorithms if requested.

## Considering Refraction

Refraction is taken into account during post processing of the data with the Hydrography AddOns available for the well known and acknowledged RIEGL ALS software package RiPROCESS. After georeferencing the acquired pointclouds, the water surface is determined and targets below the water surface are shifted to the correct position according to refraction (beam bending and waveform compression). The water surface can be defined as a simple plane but may also be represented by a detailed model determined from the laser scan data.

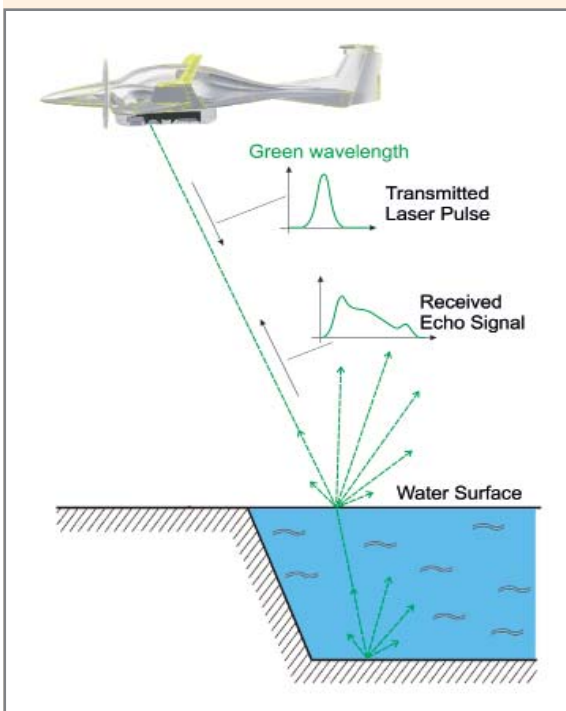
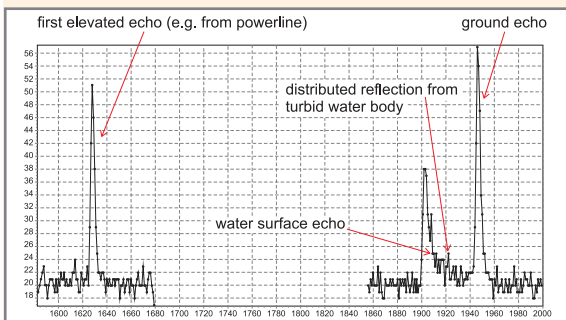

Complete Platform System  
for Hydrographic Airborne Scanning

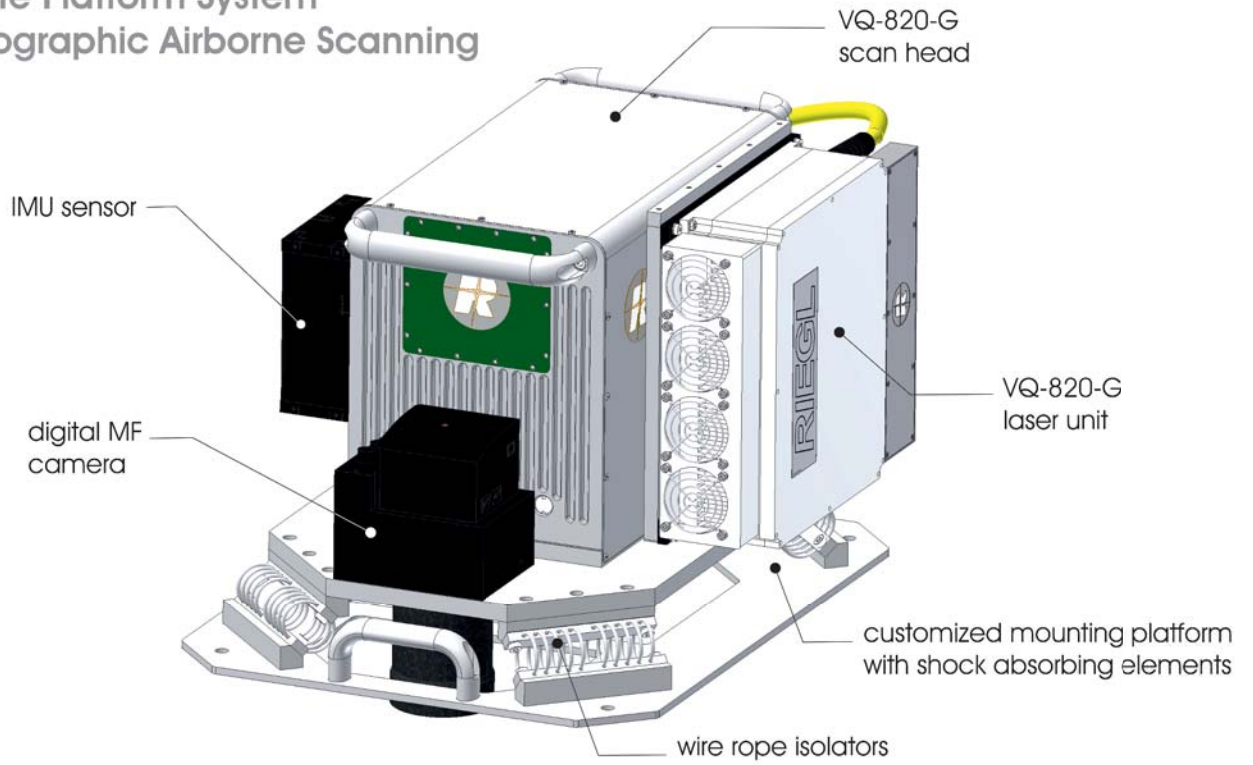

rear view

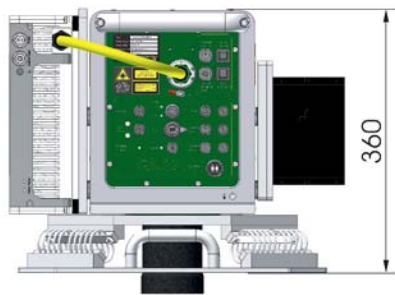

bottom view

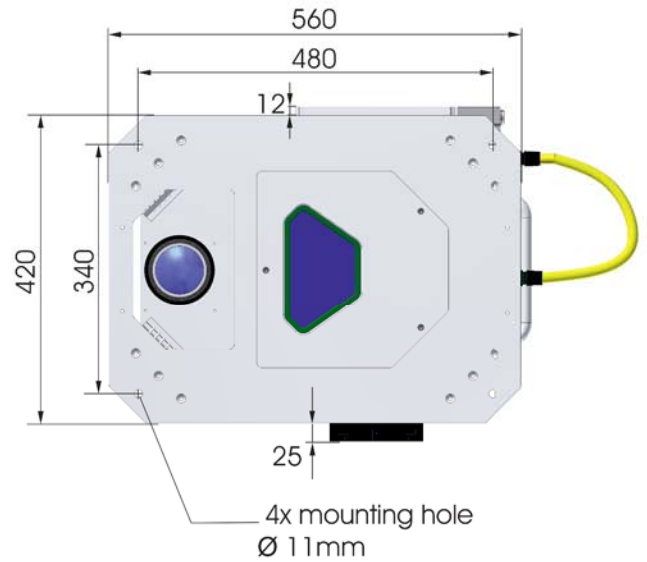

front view

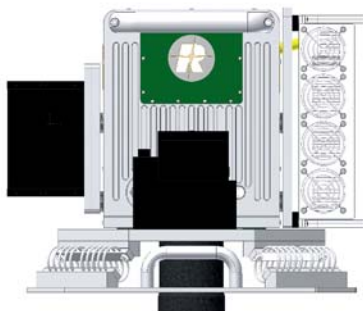



Scan Head

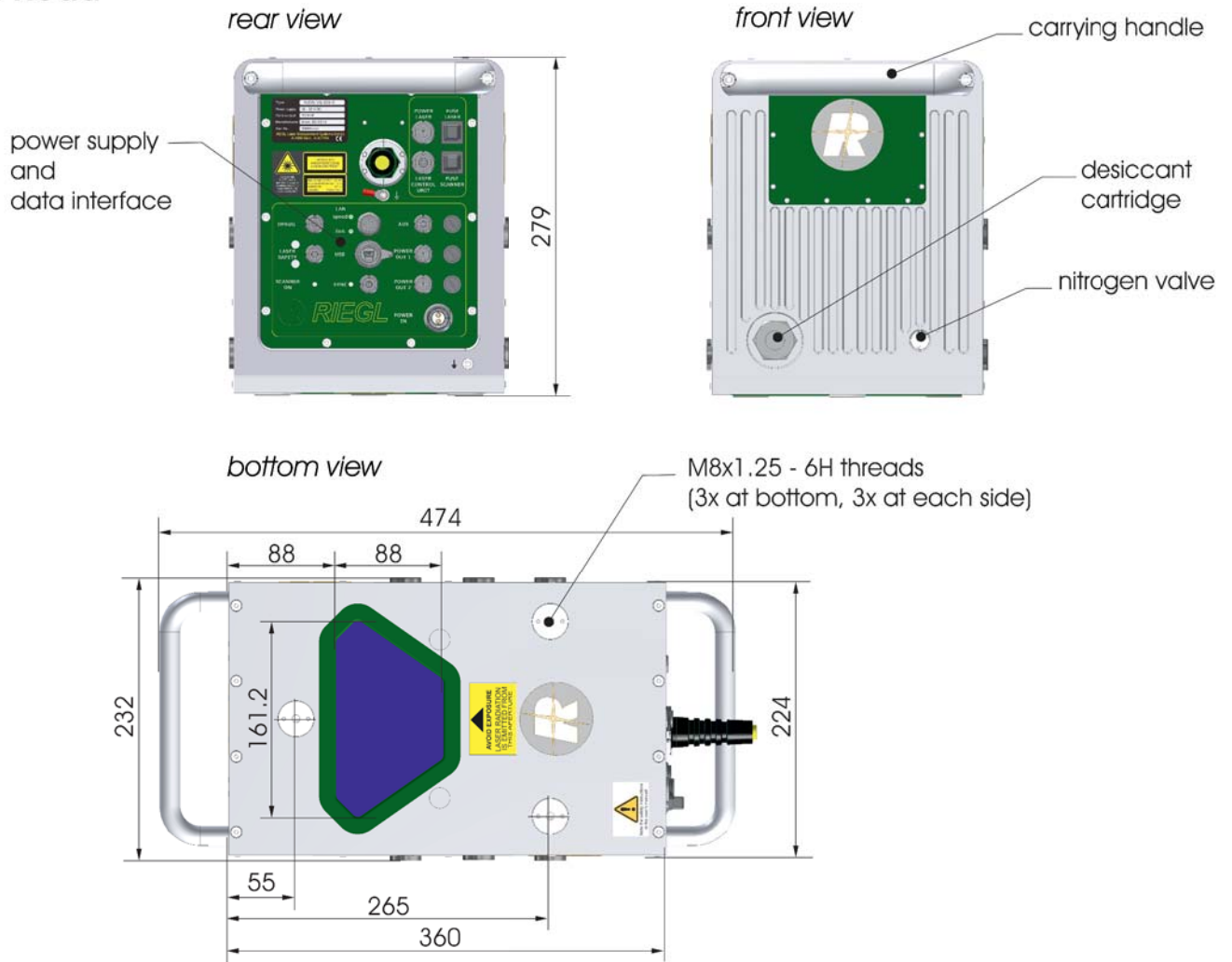

Laser Unit

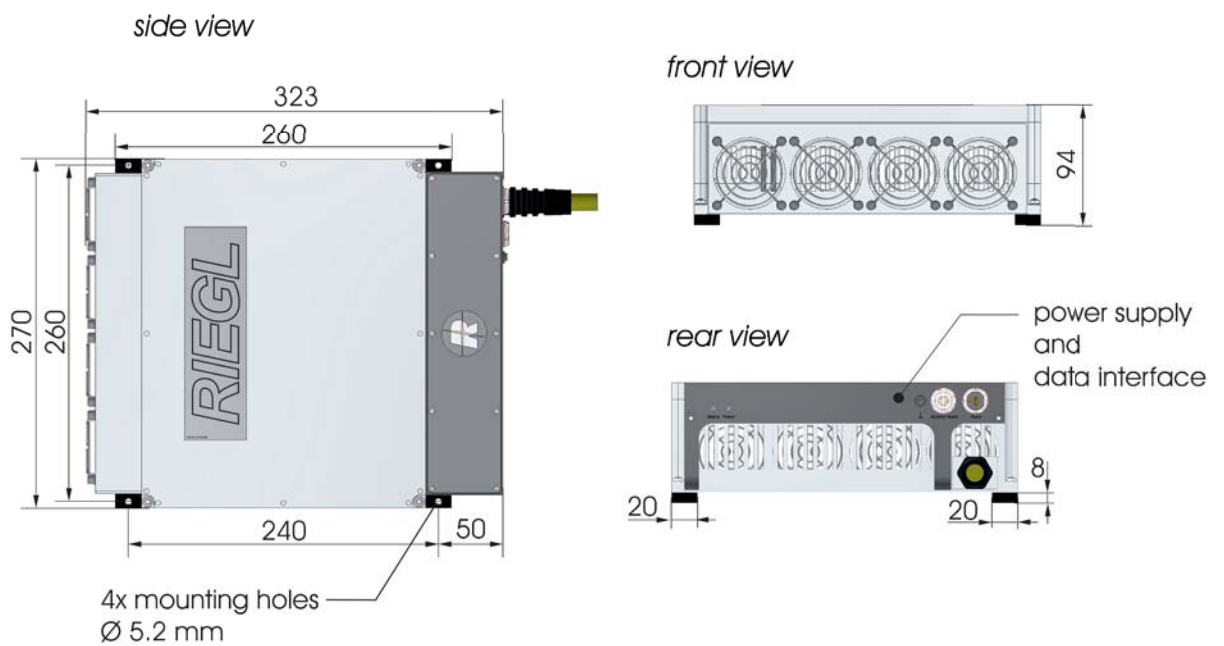

all dimensions in mm

## Floodplain Area Alongside the Danube

A small floodplain area alongside the Danube in Lower Austria was chosen where several waterbodies of different size and depth are available. The waterbodies were partly covered with a thin layer of ice. At windless conditions, the water surface was perfectly flat.

**VQ-820-G measurements were performed from a helicopter platform at the following parameters:**

<i>Operating altitude:</i>	125 m AGL
<i>Ground speed:</i>	25 knots
<i>Laser pulse repetition rate:</i>	138kHz
<i>Scanning rate:</i>	70 lines/second
<i>Resulting point density:</i>	50 meas./square meter



Snapshot from a nadir-pointed video camera also showing the thin ice layer and several power lines going over the waterbody.

Perspective view of the flight strip with and without subaqueous points as well as the power lines. The point cloud of the power lines with masts gives a good impression of the very high measurement resolution.

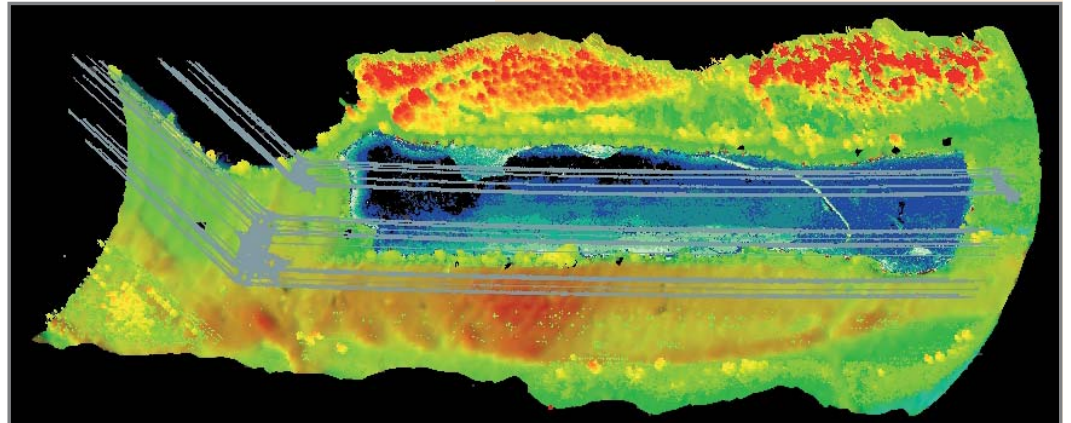

Cross section indicating targets above water level, subaqueous points, natural land targets and power lines.

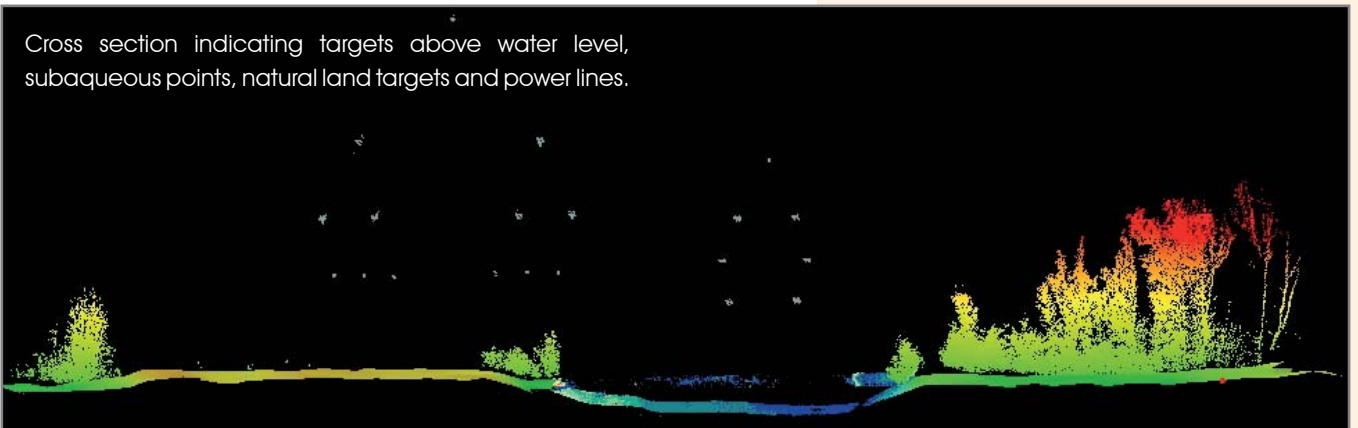

# Technical Data RIEGL VQ®-820-G

## Export Classification

The Hydrographic Airborne Laser Scanner VQ-820-G has been designed and developed for commercial topographic, hydrographic, and bathymetric surveying applications.

The VQ-820-G is subject to export restrictions as set up by the Wassenaar Arrangement. It is classified as dual-use good according to position number 6A8j3 of the official Dual-Use-List to be found on site <http://www.wassenaar.org>. Within the European Union, Council Regulation (EC) No 428/2009 implements the export restrictions of the Wassenaar Arrangement. The corresponding position number is **6A008j3**.

## Laser Product Classification

Laser Class

Class 3B Laser Product according to IEC60825-1:2007

The following clause applies for instruments delivered into the United States: Complies with 21 CFR 1040.10 and 1040.11 except for deviations pursuant to Laser Notice No. 50, dated June 24, 2007. The Instrument must be used only in combination with the appropriate laser safety box.

NOHD <sup>1) 2)</sup>  
ENOHD <sup>1) 2)</sup>

100 m  
600 m

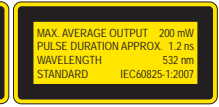

1) (E)NOHD ... (Extended) Nominal Ocular Hazard Distance

2) If it can be assumed that potential viewers are hit by a single pulse only (e.g., when the instrument is mounted on a platform moving so fast that the pulses do not overlap at the (E)NOHD.)

## Range Measurement Performance

Measuring Principle

Topography (diffusely reflecting targets)

Max. Measurement Range <sup>3) 4)</sup>

natural targets  $\rho \geq 20\%$

natural targets  $\rho \geq 60\%$

Typ. Operating Flight Altitude AGL <sup>5)</sup>

Hydrography

Typ. Measurement Range <sup>4)</sup>

Typ. Operating Flight Altitude AGL

Minimum Range

Accuracy <sup>7) 9)</sup>

Precision <sup>8) 9)</sup>

Laser Pulse Repetition Rate

Max. Effective Measurement Rate

Echo Signal Intensity

Number of Targets per Pulse

Laser Wavelength

Laser Beam Divergence

Laser Beam Footprint (Gaussian Beam Definition)

time of flight measurement, echo signal digitization, online waveform processing

1 500 m  
2 500 m  
1 200 m (3 900 ft.)

1 Secchi depth <sup>6)</sup>  
600 m (1 970 ft.)

10 m  
25 mm

25 mm  
up to 520 kHz <sup>10)</sup>

up to 200 000 meas./sec. (@ 520 kHz PRR & 42° FOV)

for each target, high-resolution 16 bit intensity information is provided

unlimited (digitized waveform processing)

green

1.0 mrad <sup>11)</sup>

100 mm @ 100 m, 1000 mm @ 1000 m

- 3) The following conditions are assumed: target larger than the footprint of the laser beam, average ambient brightness, visibility 23 km, perpendicular angle of incidence, ambiguity resolved by multiple-time-around processing.  
4) In bright sunlight the operational range may be considerably shorter than under an overcast sky.  
5) Reflectivity  $\rho \geq 20\%$ , 42° FOV, additional roll angle  $\pm 5^\circ$   
6) The Secchi depth is defined as the depth at which a standard black and white disc deployed into the water is no longer visible to the human eye.

- 7) Accuracy is the degree of conformity of a measured quantity to its actual (true) value.  
8) Precision, also called reproducibility or repeatability, is the degree to which further measurements show the same result.  
9) topography, one sigma @ 150m range under RIEGL test conditions.  
10) Rounded values  
11) Measured at the  $1/e^2$  points. 1.0 mrad corresponds to an increase of 100 cm of beam diameter per 1000 m distance.

## Scanner Performance

Scanning Mechanism

Scan Pattern

Field of View (selectable)

Scan Speed (selectable)

Angular Step Width  $\Delta \vartheta$  (selectable)

between consecutive laser shots

Angle Measurement Resolution

rotating multi-facet mirror

section of an ellipse

42°, max. 60° (with reduced measurement range)

50 - 200 scans/sec

$\Delta \vartheta \geq 0.01^\circ$  (for PRR 520 kHz)

0.001°

## Data Interfaces

Configuration

Scan Data Output

GNSS Interface

LAN 10/100/1 000 Mbit/sec

LAN 10/100/1 000 Mbit/sec, USB 2.0

Serial RS232 interface for data string with GNSS-time information,

TTL input for 1PPS synchronization pulse

## Mechanical Interfaces

Mounting of Scan Head

Mounting of IMU Sensor

3 x M8 thread inserts in the base plate

3 x M8 thread inserts at both sides of the housing

(rigidly coupled with the internal mechanical structure)

## General Technical Data

Power Supply Input Voltage

Current Consumption

Main Dimensions

Weight

Humidity

Protection Class Scan Head

Max. Flight Altitude (operating / not operating) <sup>12)</sup>

Temperature Range

Scan Head

18 - 32 V DC

typ. 65 W

360 x 232 x 279 mm

approx. 16 kg

non condensing

IP54, dust and splash-proof

16 500 ft (5 000 m) above MSL / 18 000 ft (5 500 m) above MSL

+10°C up to +40°C (operation) / -10°C up to +50°C (storage)

Laser Unit

18 - 32 V DC

typ. 120 W

323 x 270 x 94 mm

approx. 9.5 kg

12) For standard atmospheric conditions: 1013 mbar, +15°C at sea level



RIEGL Laser Measurement Systems GmbH, 3580 Horn, Austria  
Tel.: +43-2982-4211, Fax: +43-2982-4210, E-mail: [office@riegl.co.at](mailto:office@riegl.co.at)

RIEGL USA Inc., Orlando, Florida 32819, USA  
Tel.: +1-407-248-9927, Fax: +1-407-248-2636, E-mail: [info@rieglusa.com](mailto:info@rieglusa.com)

RIEGL Japan Ltd., Tokyo 1640013, Japan  
Tel.: +81-3-3382-7340, Fax: +81-3-3382-5843, E-mail: [info@riegl-japan.co.jp](mailto:info@riegl-japan.co.jp)

[www.riegl.com](http://www.riegl.com)